

MIP

PLANETARY MIXER



CERTIFIED COMPANY
UNI EN ISO 9001



SINCE 1947



SICOMA



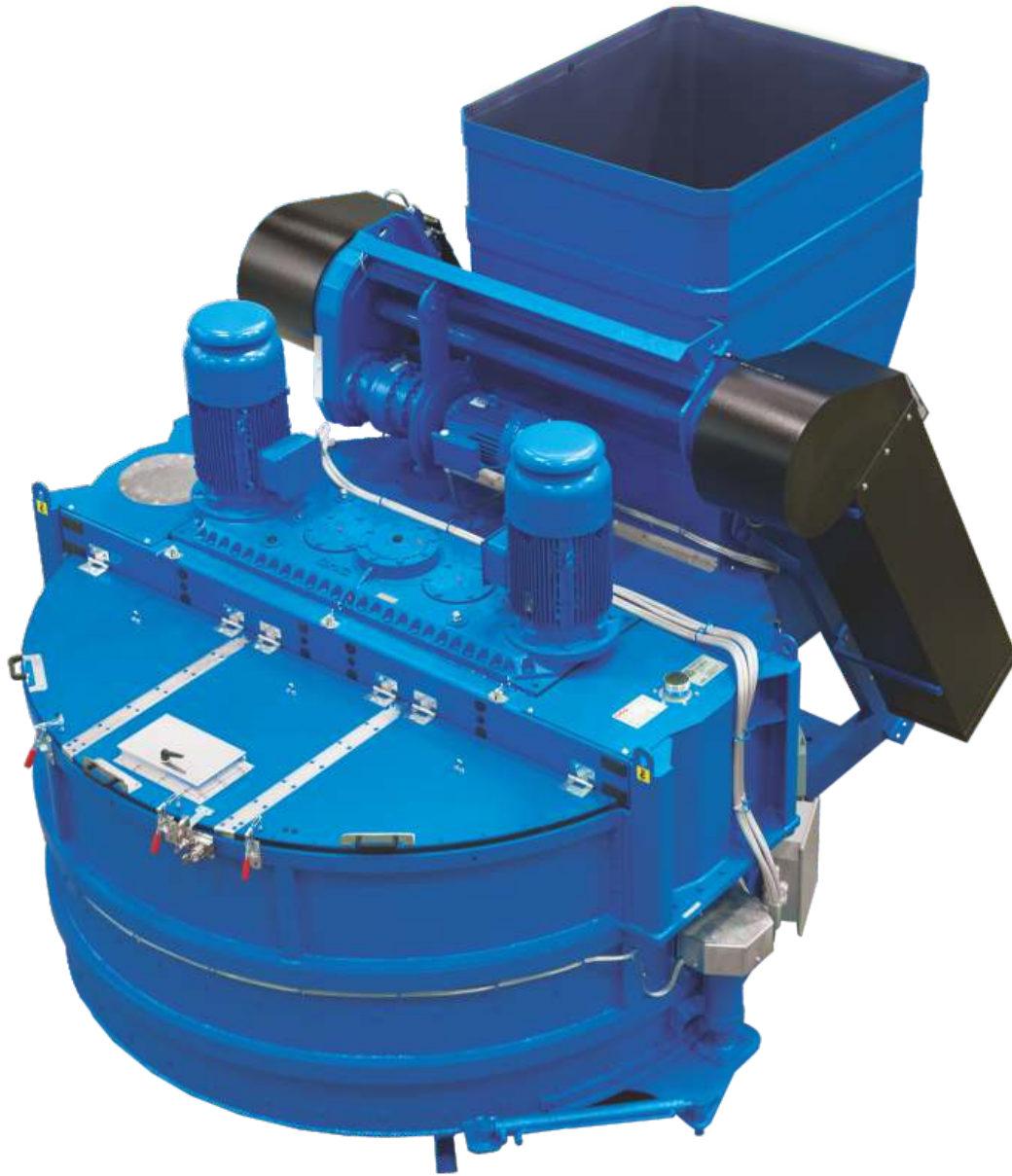

WIDE RANGE OF MIXERS & CUSTOMIZED SOLUTIONS

The size of our Planetary Mixers ranges from 10 to 4000 liters of compacted concrete output, covering every possible need from small laboratory mixers to the largest production plants. The excellent performance of SICOMA-OMG Planetary Mixers are recognized in several application fields: readymix concrete, production of prestressed / precast elements, block and pavers, concrete pipes, dry mortar mix, but also in different sectors such as glass, refractory materials for foundries and chemical products. Depending on the type of application, the mixers can be equipped with several accessories and options to optimize their productivity, mixing quality and life expectancy. Whenever necessary, we work with our customers in the development of new solutions that best suit their specific needs.

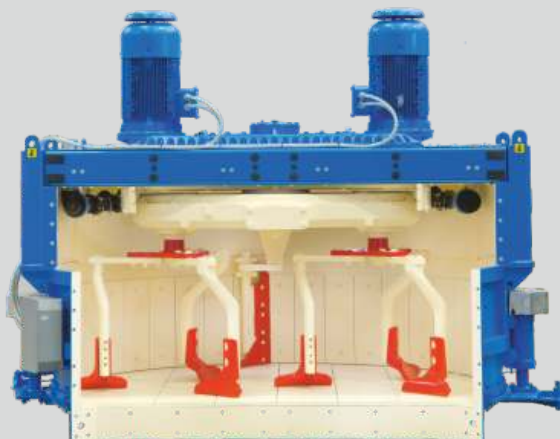

GEARBOX

With 70 years of mechanical experience, Sicoma has created a gearbox virtually indestructible. The huge double horizontal design is strong and shock resistant. The wide horizontal oil bath is cool running and gives every gear optimum lubrication. It is good for life and carries a 5 year, 10,000 hour warranty.

Up to 4000



Up to 2500



Up to 1000

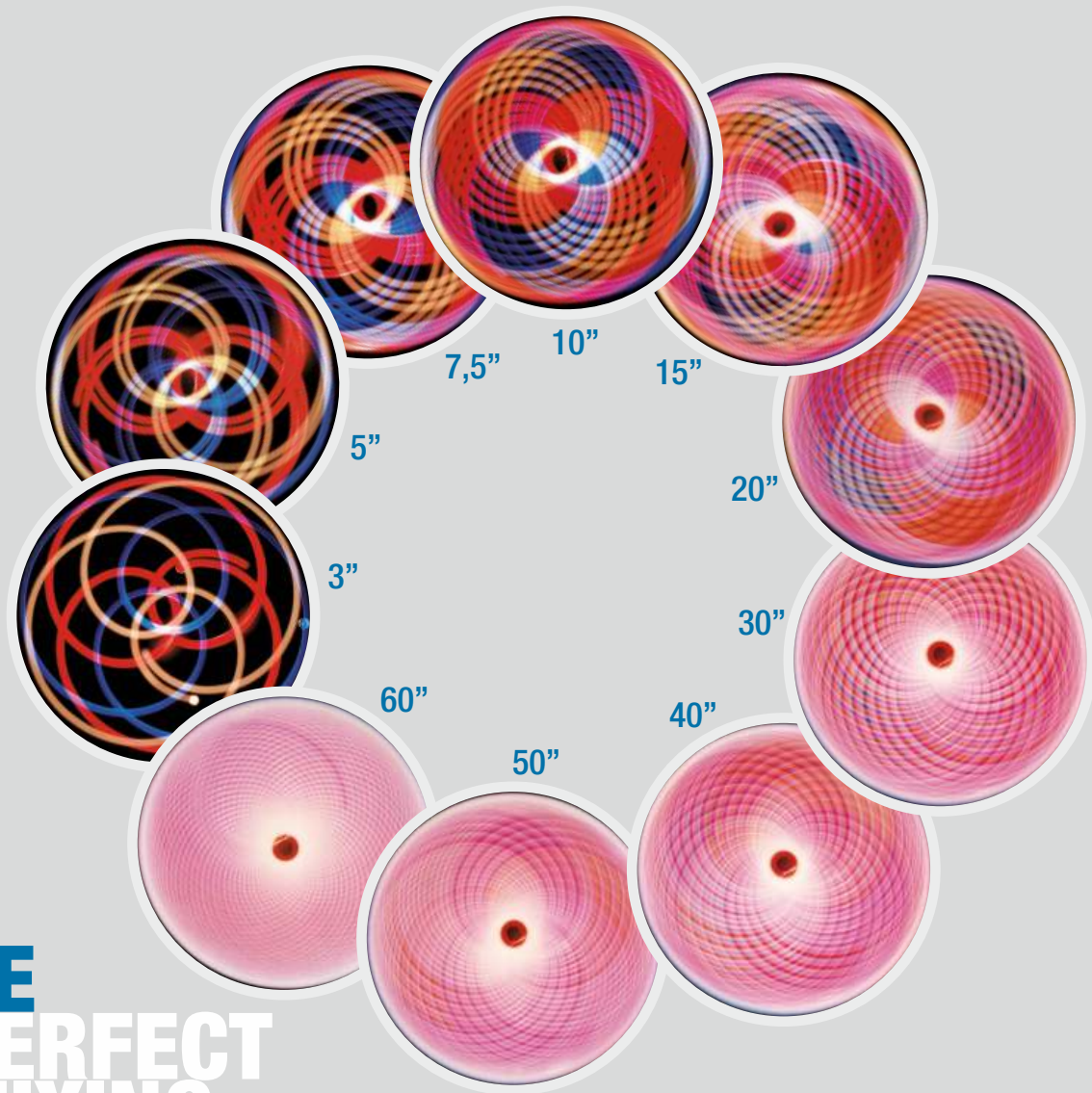
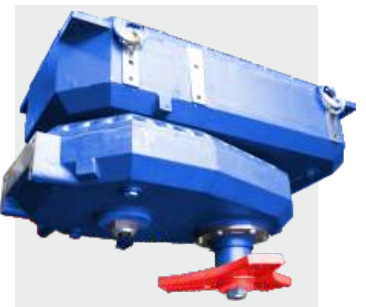

**THE
PERFECT
MIXING**

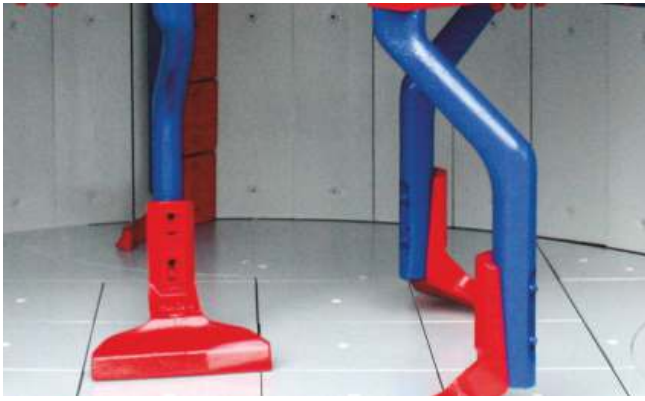

MIXING BLADES

Complete the mixing action and give fast discharge. Cast from Ni-hard iron, 550 HB minimum, for extreme wear resistance. Outer edges are thickened to equalize wear and the angle of attack is optimized to push, not slice, to maximize both mixing and blade life.



LINER PLATES

15 mm Ni-hard cast iron tiles give many times the life of abrasion resistant steel liner plates, reducing lifetime cost. Bolted assembly makes replacement a simple task; in addition, the wall plates are reversible to increase life even further. Additionally, tight fabrication tolerances mean that blades can be adjusted close to walls and floor for perfect cleanout between batches, ensuring the best performance on coloured products.

MIXING ARMS

SICOMA's mixing action starts with the arms, which are responsible for most of the mixing, from top to bottom. Three cast iron arms per star, two stars starting from MP 1875/1250 and three stars for MP 4500/3000 and MP6000/4000. Together with two hardened steel scraping arms they are the best for toughness plus abrasion resistance. Adjustment slots allow easy blade adjustment to compensate for wear.

HYDRAULIC POWER PACK

It has plenty of capacity to operate doors reliably in even the largest mixer. Manual lever allows the door dual use, to be opened during power loss and to be closed right after.



DISCHARGE

Up to four swing-out sector doors running in rubber seals are completely watertight, non-jamming and low in maintenance, further reducing lifetime cost. All models are hydraulically powered, but for small ones is also available a choice between pneumatic or manual operation.

HALF-MOON COVER

Widest opening of any, to give faster cleanup and adjustment of wear parts while making the process safer all round. One, two or three-part depending on mixer size. Single piece cover with hydraulic lift for easiest access is optional in largest models.

OPTIONS AVAILABLE

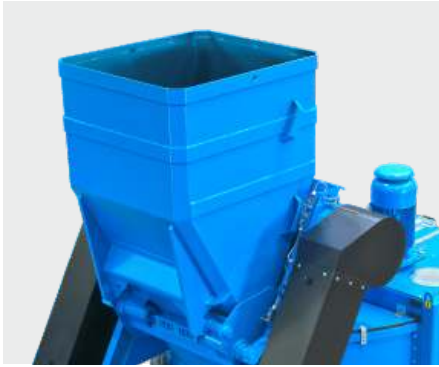

SKIP FOR AGGREGATE LOADING

Skip hoist is available for all sizes of MP mixers. The Twin Drum hoist equalizes the load and prevents the skip bucket from falling in case of cable failure. Slack cable detectors also give the most reliable and safe operation.



CEMENT AND WATER SCALES

All MP mixers can be equipped with the weighing hoppers for Cement and Water. They are fixed to the mixer tank and preassembled in the factory to minimize the erection time of the plant at the jobsite.



WATER FLOWMETER

As an alternative to the water scale, water can be measured by a flowmeter. In some applications it is basically used for the moisture correction of the batch in conjunction with a moisture probe.



AGGREGATE HOLDING HOPPER

This accessory is strongly recommended to allow the mixer to reach its nominal productivity. Preassembled in the factory, it is equipped with an OMG Sicoma butterfly valve driven by the hydraulic power pack of the mixer.



BOTOMATIC DISCHARGE DOOR

For slurry / bitumen mixtures and for powder blending, the use of the special "botomatic" door makes the tank perfectly leakage proof. This is particularly critical when the tank is pressurized (due to gas injection) or de-pressurized.



SIDE ACCESS DOOR

Whenever the access from the top cover to the tank is impossible or too difficult, the side access door is the right solution. This option is also recommended for special mixtures in order to improve the cleaning of the tank.



HIGH SPEED AGITATOR

The function of this additional device depends on the type of mixture, speed and blade configuration. For dry mix, it increases the dispersion of the materials whereas for low water mixtures it crushes the possible lumps generated by the mixing.



HIGH PRESSURE WASHING SYSTEM

Using the unique feature of the hollow shaft of the OMG Gearbox, the high pressure pipe reaches the center of the machine allowing the washout jets to be mounted under the scraping arms. All nozzles are adjustable to cover all spots for a high efficiency cleaning.



DUST COLLECTOR AIRBAG

During the aggregate loading into the mixer from a holding hopper, the Dust Collector Bag absorbs the air shock generated by the fast inrush of the material. The function of the airbag is very important for dust containment, in conjunction with an active filter.

OPTIONS AVAILABLE



FLOOR MOUNTED MOISTURE PROBE

The production of high quality concrete usually requires a moisture measurement in the mixer, in order to control the water content in the mix. Upon request, all Planetary Mixers can be equipped with moisture probes installed at the floor level.



PROBE CLEANING BLADE

In case a floor mounted probe is installed, we recommend using a rubber cleaning blade which cleans the surface of the sensor at every rotation of the planetary gearbox, improving the quality of the measurement.



ROTATING MOISTURE PROBE

Due to the hollow main shaft (unique feature of OMG Gearbox), MP Mixers can be equipped with a moisture probe which is fixed to the scraping arm and rotating into the mixture. The probe cables are connected to the control system through a rotating collector.

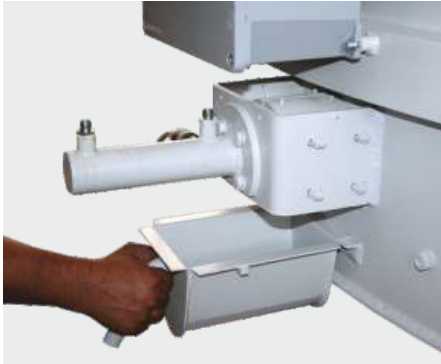

HYDRAULIC SAMPLING BOX

All Planetary mixers can be equipped with a sampling box to take samples of material before the discharge, typically used to prepare test cubes. The operator can collect the sample easily and safely without stopping the mixer and opening the top cover.



BELT TRANSMISSION

In case the mixer must be installed in a plant with a reduced height dimension, it is possible to install the mixer motor at the side of the tank and to use a belt transmission between the motor and the gearbox. This solution is typically used for retrofits or mobile plants.



MANUAL CONTROL PANEL

Mounts on the mixer, allowing major mixer functions to be controlled locally to make cleanout, testing and maintenance easier.



DISCHARGE DOOR SAFETY GUARD

When the service platform of the mixer is installed under the discharge door, it is necessary to use a protection guard to keep the operators safe during the rotation of the door sector. This safety guard can also be dust proof when the mixer works with dry mixes.



HYDRAULIC COUPLING

Gives long service life by reducing the high mechanical stress in conditions such as repeated startup with a full load.



STAINLESS STEEL TANK AND MIXING TOOLS

Whenever the material to be mixed must be contamination free or when the ingredients are chemically aggressive, it is recommended to use special materials (such as Stainless Steel) for the lining of the pan and for the mixing tools.

MP WITH SKIP

MP WITHOUT SKIP

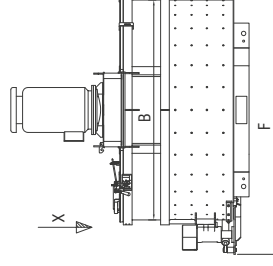
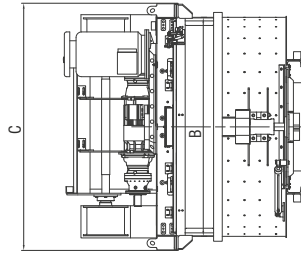
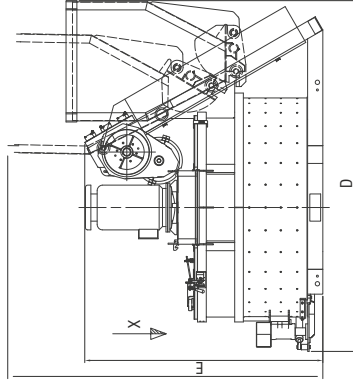
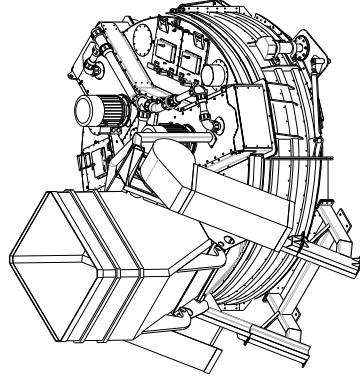

TYPE	MP 75/50	MP 150/100	MP 375/250	MP 565/375	MP 750/500	MP 1125/750	MP 1500/1000	MP 1875/1250	MP 2250/1500	MP 3000/2000	MP 3750/2500	MP 4500/3000	MP 6000/4000
DRY FILLING CAPACITY (*)	75	150	375	565	750	1125	1500	1875	2250	3000	3750	4500	6000
CONCRETE OUTPUT PER CYCLE (COMPACTED) (*)	50	100	250	375	500	750	1000	1250	1500	2000	2500	3000	4000
MAXIMUM LOAD CAPACITY	120	240	600	900	1200	1800	2400	3000	3600	4800	6000	7200	9600
SKIP VOLUMETRIC CAPACITY	85	165	412	616	825	1237	1650	2060	2475	3300	4125	4390	6000
MAXIMUM SKIP LOAD CAPACITY	100	200	500	750	1000	1500	2000	2500	3000	4000	5000	6000	8000
MIXING MOTOR (S)	2,2 / 3	5,5 / 7,5	7,5 / 10	11 / 15	18,5 / 25	30 / 40	55 / 75	55 / 75	2 x 30 / 40	2 x 45 / 60	2 x 55 / 75	3 x 45 / 60	3 x 55 / 75
HYDRAULIC POWER PACK MOTOR	0,75 / 1	0,75 / 1	1,5 / 2	1,5 / 2	1,5 / 2	2,2 / 3	4 / 5,5	4 / 5,5	4 / 5,5	5,5 / 7,5	5,5 / 7,5	7,5 / 10	7,5 / 10
SPEED OF PLANETARY GEARBOX	20	20	20	20	20	20	20	15	15	15	15	10	10
SPEED OF MIXING STAR(S)	50	35	40	40	45	40	45	40+40	30+30	30+30	30+30	30+30+30	30+30+30
MIXING ARMS	3	3	3	3	3	3	3	6	6	6	6	9	9
SCRAPING ARMS(S)	1	1	1	1	1	1	1	1	1	2	2	3	3
WEIGHT OF MIXER WITHOUT SKIP	200	500	900	1400	2000	2700	3700	4700	6300	8500	9000	16000	17400
WEIGHT OF MIXER WITH SKIP	400	900	1400	2000	2700	3700	4900	5900	8400	12000	12900	20530	22355
A - MAXIMUM HEIGHT FOR SKIP OPERATION	---	1710	1790	2140	2491	2970	3158	3680	3486	4200	4578	4506	---
B - TANK DIAMETER	710	1010	1270	1590	1835	2015	2215	2400	2612	3526	3526	4100	4100
C - MAXIMUM WIDTH	886	1206	1530	1870	2100	2270	2470	2690	2890	3696	3696	4370	---
D - MAXIMUM LENGHT FOR TRANSPORT	---	1906	2300	2620	2955	3400	3885	4072	4340	4868	4868	5550	---
E - MAXIMUM HEIGHT (WITHOUT SKIP)	1461	1530	1352	1690	1836	2180	2250	2412	2386	2544	2601	2450	---
F - MAXIMUM LENGHT (WITHOUT SKIP)	823	1220	1575	1980	2155	2380	2560	2750	2980	3790	3790	4600	4600

(*) In order to identify the productivity of the mixer, two parameters must be taken into consideration:

1. Maximum Weight of the Mix, on the basis of the usual specific weight of concrete (150 lb/ft³ or 2400 kg/m³). 2. Maximum Volume occupied by all batch components charged into the mixer, not exceeding the Dry Filling Capacity. For more information about productivity and accessories, please contact our Sales Department. All technical data are subject to change without notice due to technical improvement. Values indicated are not applicable in all applications and conditions and are subject to variations depending on the use and quantity of the product.

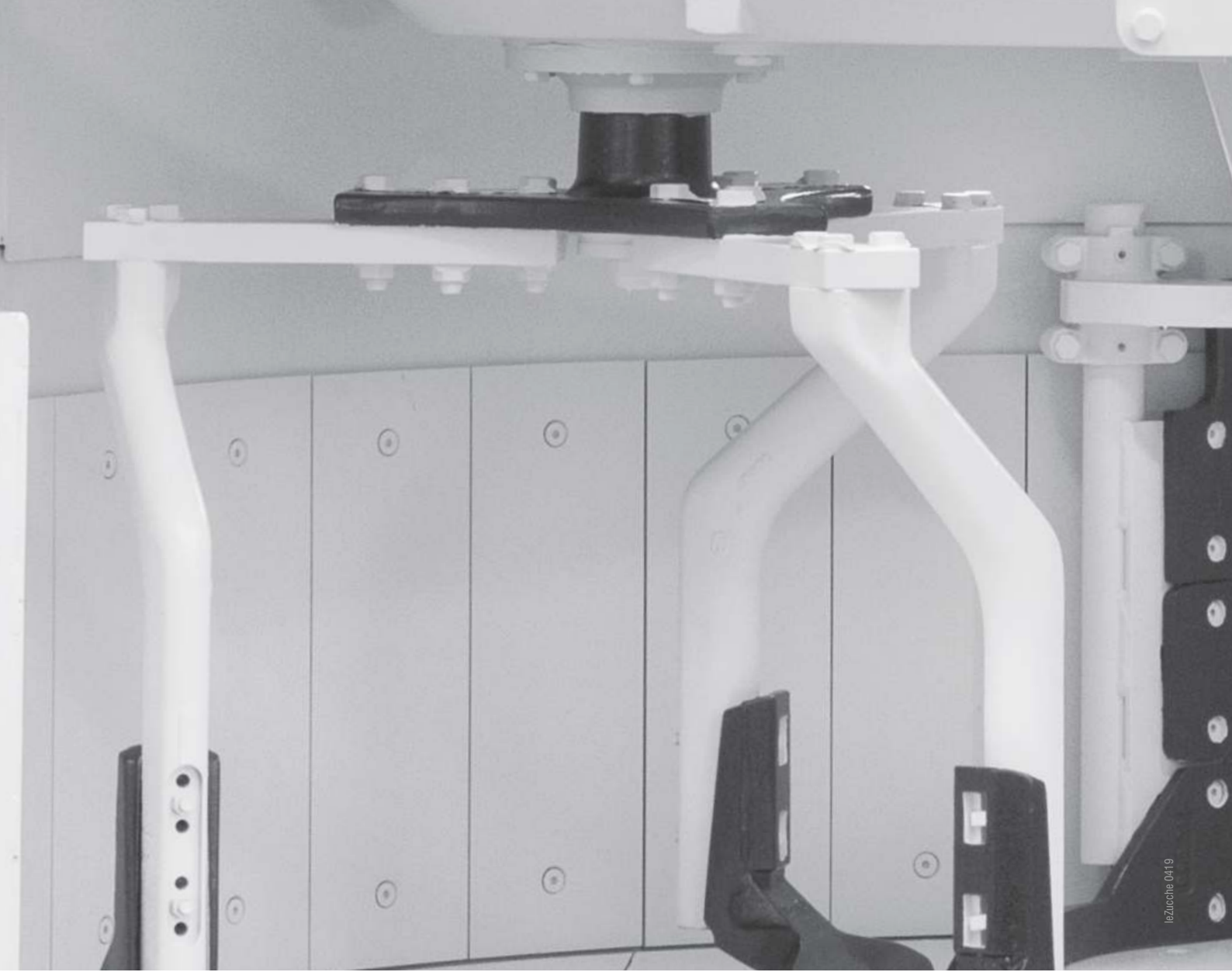

laZucche 0419



SICOMA



S.I.CO.MA. srl Via Brenta, 3 - 06135 - Perugia - Italy Tel. +39 075 592.81.20 Fax +39 075 592.83.71

**OFFICINE
MECCANICHE
GALLETTI**

SICOMA

**GALLETTI
IBÉRICA**

**OMG
FRANCE**

**SICOMA
NORTH
AMERICA**

**SICOMA
ZHUHAI**

**OMG
SICOMA
ADO**

**SICOMA
INDIA**

www.sicoma.it

sicoma@sicoma.it